

Voltage Output, High or Low Side Measurement, Bi-Directional Zero-Drift Series Current-Shunt Monitor

Check for Samples: [INA210](#), [INA211](#), [INA212](#), [INA213](#), [INA214](#)

FEATURES

- **WIDE COMMON-MODE RANGE:** -0.3V to 26V
- **OFFSET VOLTAGE:** $\pm 35\mu\text{V}$ (Max, INA210)
(Enables shunt drops of 10mV full-scale)
- **ACCURACY:**
 - $\pm 1\%$ Gain Error (Max over temperature)
 - $0.5\mu\text{V}/^\circ\text{C}$ Offset Drift (Max)
 - $10\text{ppm}/^\circ\text{C}$ Gain Drift (Max)
- **CHOICE OF GAINS:**
 - INA210: $200\text{V}/\text{V}$
 - INA211: $500\text{V}/\text{V}$
 - INA212: $1000\text{V}/\text{V}$
 - INA213: $50\text{V}/\text{V}$
 - INA214: $100\text{V}/\text{V}$
- **QUIESCENT CURRENT:** $100\mu\text{A}$ (max)
- **SC70 PACKAGE:** All Models
- **THIN QFN PACKAGE:** INA210, INA213, INA214

APPLICATIONS

- **NOTEBOOK COMPUTERS**
- **CELL PHONES**
- **TELECOM EQUIPMENT**
- **POWER MANAGEMENT**
- **BATTERY CHARGERS**
- **WELDING EQUIPMENT**

DESCRIPTION

The INA210, INA211, INA212, INA213, and INA214 are voltage output current shunt monitors that can sense drops across shunts at common-mode voltages from -0.3V to 26V , independent of the supply voltage. Five fixed gains are available: $50\text{V}/\text{V}$, $100\text{V}/\text{V}$, $200\text{V}/\text{V}$, $500\text{V}/\text{V}$, or $1000\text{V}/\text{V}$. The low offset of the Zero-Drift architecture enables current sensing with maximum drops across the shunt as low as 10mV full-scale.

These devices operate from a single $+2.7\text{V}$ to $+26\text{V}$ power supply, drawing a maximum of $100\mu\text{A}$ of supply current. All versions are specified over the extended operating temperature range (-40°C to $+125^\circ\text{C}$), and offered in an SC70 package. The INA210, INA213, and INA214 are also offered in a thin QFN package.

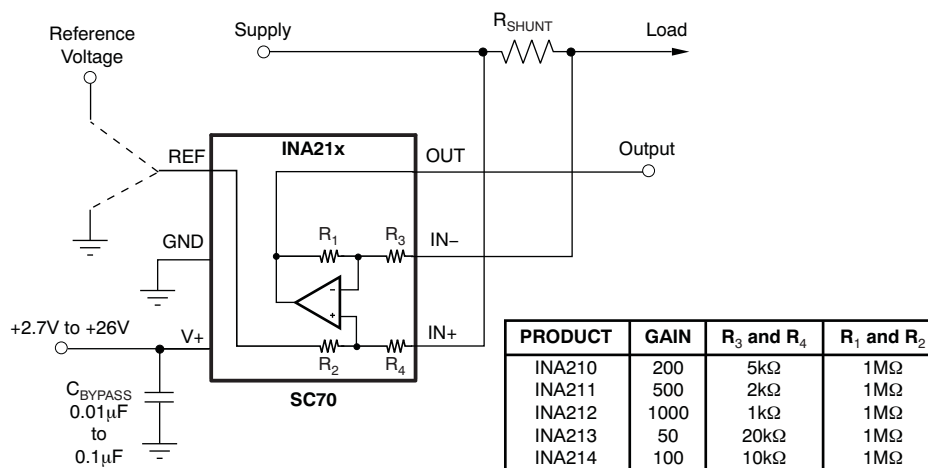

Please be aware that an important notice concerning availability, standard warranty, and use in critical applications of Texas Instruments semiconductor products and disclaimers thereto appears at the end of this data sheet.

All trademarks are the property of their respective owners.



This integrated circuit can be damaged by ESD. Texas Instruments recommends that all integrated circuits be handled with appropriate precautions. Failure to observe proper handling and installation procedures can cause damage.

ESD damage can range from subtle performance degradation to complete device failure. Precision integrated circuits may be more susceptible to damage because very small parametric changes could cause the device not to meet its published specifications.

PACKAGE/ORDERING INFORMATION⁽¹⁾

PRODUCT	GAIN	PACKAGE	PACKAGE DESIGNATOR
INA210A	200V/V	SC70-6	DCK
	200V/V	Thin QFN-10	RSW
INA210B	200V/V	SC70-6	DCK
	200V/V	Thin QFN-10	RSW
INA211A	500V/V	SC70-6	DCK
INA211B	500V/V	SC70-6	DCK
INA212A	1000V/V	SC70-6	DCK
INA212B	1000V/V	SC70-6	DCK
INA213A	50V/V	SC70-6	DCK
	50V/V	Thin QFN-10	RSW
INA213B	50V/V	SC70-6	DCK
	50V/V	Thin QFN-10	RSW
INA214A	100V/V	SC70-6	DCK
	100V/V	Thin QFN-10	RSW
INA214B	100V/V	SC70-6	DCK
	100V/V	Thin QFN-10	RSW

(1) For the most current package and ordering information, see the Package Option Addendum at the end of this document, or visit the device product folder at www.ti.com.

ABSOLUTE MAXIMUM RATINGS⁽¹⁾

Over operating free-air temperature range, unless otherwise noted.

		INA210, INA211, INA212, INA213, INA214	UNIT
Supply Voltage		+26	V
Analog Inputs, V_{IN+} , V_{IN-} ⁽²⁾	Differential (V_{IN+})–(V_{IN-})	–26 to +26	V
	Common-Mode ⁽³⁾	GND–0.3 to +26	V
REF Input		GND–0.3 to (V+) + 0.3	V
Output ⁽³⁾		GND–0.3 to (V+) + 0.3	V
Input Current into Any Pin ⁽³⁾		5	mA
Operating Temperature		–55 to +150	°C
Storage Temperature		–65 to +150	°C
Junction Temperature		+150	°C
ESD Ratings (version A):	Human Body Model (HBM)	4000	V
	Charged-Device Model (CDM)	1000	V
	Machine Model (MM)	200	V
ESD Ratings (version B):	Human Body Model (HBM)	1500	V
	Charged-Device Model (CDM)	1000	V
	Machine Model (MM)	100	V

(1) Stresses above these ratings may cause permanent damage. Exposure to absolute maximum conditions for extended periods may degrade device reliability. These are stress ratings only, and functional operation of the device at these or any other conditions beyond those specified is not implied.

(2) V_{IN+} and V_{IN-} are the voltages at the IN+ and IN– pins, respectively.

(3) Input voltage at any pin may exceed the voltage shown if the current at that pin is limited to 5mA.

ELECTRICAL CHARACTERISTICS

Boldface limits apply over the specified temperature range, $T_A = -40^{\circ}\text{C}$ to $+125^{\circ}\text{C}$.

At $T_A = +25^{\circ}\text{C}$, $V_{\text{SENSE}} = V_{\text{IN}+} - V_{\text{IN}-}$.

INA210, INA213, and INA214: $V_S = +5\text{V}$, $V_{\text{IN}+} = 12\text{V}$, and $V_{\text{REF}} = V_S/2$, unless otherwise noted.

INA211 and INA212: $V_S = +12\text{V}$, $V_{\text{IN}+} = 12\text{V}$, and $V_{\text{REF}} = V_S/2$, unless otherwise noted.

PARAMETER	CONDITIONS	INA210, INA211, INA212, INA213, INA214			UNIT	
		MIN	TYP	MAX		
INPUT						
Common-Mode Input Range	V_{CM}	Version A	-0.3		26	V
		Version B	-0.1		26	V
Common-Mode Rejection	CMR	$V_{\text{IN}+} = 0\text{V}$ to $+26\text{V}$, $V_{\text{SENSE}} = 0\text{mV}$				
			INA210, INA211, INA212, INA214	105	140	
Offset Voltage, RTI ⁽¹⁾	V_{OS}	$V_{\text{SENSE}} = 0\text{mV}$				
INA210, INA211, INA212			± 0.55	± 35		μV
INA213			± 5	± 100		μV
INA214			± 1	± 60		μV
vs Temperature	dV_{OS}/dT		0.1	0.5		$\mu\text{V}/^{\circ}\text{C}$
vs Power Supply	PSR	$V_S = +2.7\text{V}$ to $+18\text{V}$, $V_{\text{IN}+} = +18\text{V}$, $V_{\text{SENSE}} = 0\text{mV}$	± 0.1	± 10		$\mu\text{V}/\text{V}$
Input Bias Current	I_{B}	$V_{\text{SENSE}} = 0\text{mV}$	15	28	35	μA
Input Offset Current	I_{OS}	$V_{\text{SENSE}} = 0\text{mV}$		± 0.02		μA
OUTPUT						
Gain, INA210	G			200		V/V
				500		V/V
				1000		V/V
				50		V/V
				100		V/V
Gain Error		$V_{\text{SENSE}} = -5\text{mV}$ to 5mV	± 0.02	± 1		%
vs Temperature			3	10		ppm/ $^{\circ}\text{C}$
Nonlinearity Error		$V_{\text{SENSE}} = -5\text{mV}$ to 5mV	± 0.01			%
Maximum Capacitive Load		No sustained oscillation	1			nF
VOLTAGE OUTPUT⁽²⁾						
		$R_L = 10\text{k}\Omega$ to GND				
Swing to V+ Power-Supply Rail			(V+)-0.05	(V+)-0.2		V
Swing to GND			(V_GND)+0.005	(V_GND)+0.05		V
FREQUENCY RESPONSE						
Bandwidth	GBW	$C_{\text{LOAD}} = 10\text{pF}$, INA210		14		kHz
		$C_{\text{LOAD}} = 10\text{pF}$, INA211		7		kHz
		$C_{\text{LOAD}} = 10\text{pF}$, INA212		4		kHz
		$C_{\text{LOAD}} = 10\text{pF}$, INA213		80		kHz
		$C_{\text{LOAD}} = 10\text{pF}$, INA214		30		kHz
Slew Rate	SR		0.4			V/ μs
NOISE, RTI⁽¹⁾						
Voltage Noise Density				25		nV/ $\sqrt{\text{Hz}}$

(1) RTI = referred-to-input.

(2) See Typical Characteristic curve, *Output Voltage Swing vs Output Current* (Figure 10).

ELECTRICAL CHARACTERISTICS (continued)

Boldface limits apply over the specified temperature range, $T_A = -40^{\circ}\text{C}$ to $+125^{\circ}\text{C}$.

At $T_A = +25^{\circ}\text{C}$, $V_{\text{SENSE}} = V_{\text{IN}+} - V_{\text{IN}-}$.

INA210, INA213, and INA214: $V_S = +5\text{V}$, $V_{\text{IN}+} = 12\text{V}$, and $V_{\text{REF}} = V_S/2$, unless otherwise noted.

INA211 and INA212: $V_S = +12\text{V}$, $V_{\text{IN}+} = 12\text{V}$, and $V_{\text{REF}} = V_S/2$, unless otherwise noted.

PARAMETER	CONDITIONS	INA210, INA211, INA212, INA213, INA214			UNIT
		MIN	TYP	MAX	
POWER SUPPLY					
Operating Voltage Range	V_S	+2.7		+26	V
Quiescent Current	I_Q		65	100	μA
Over Temperature				115	μA
TEMPERATURE RANGE					
Specified Range		-40		+125	$^{\circ}\text{C}$
Operating Range		-55		+150	$^{\circ}\text{C}$
Thermal Resistance	θ_{JA}				
SC70			250		$^{\circ}\text{C}/\text{W}$
Thin QFN			80		$^{\circ}\text{C}/\text{W}$

PIN CONFIGURATIONS

**DCK PACKAGE
 SC70-6
 (TOP VIEW)**

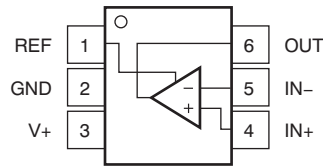

**RSW PACKAGE
 THIN QFN-10
 (TOP VIEW)**

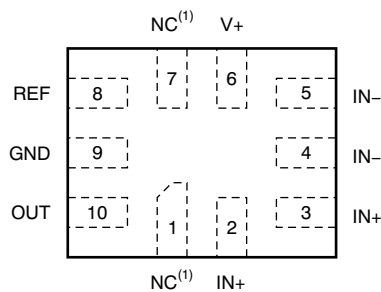

(1) NC denotes no internal connection. Pin can be left floating or connected to any voltage between V_- and V_+ .

TYPICAL CHARACTERISTICS

The INA210 is used for typical characteristics at $T_A = +25^\circ\text{C}$, $V_S = +5\text{V}$, $V_{IN+} = 12\text{V}$, and $V_{REF} = V_S/2$, unless otherwise noted.

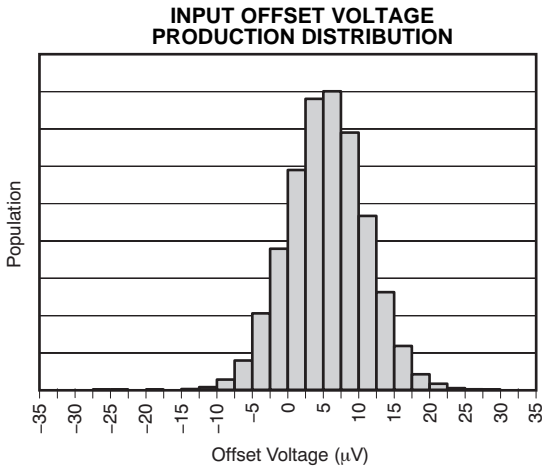

Figure 1.

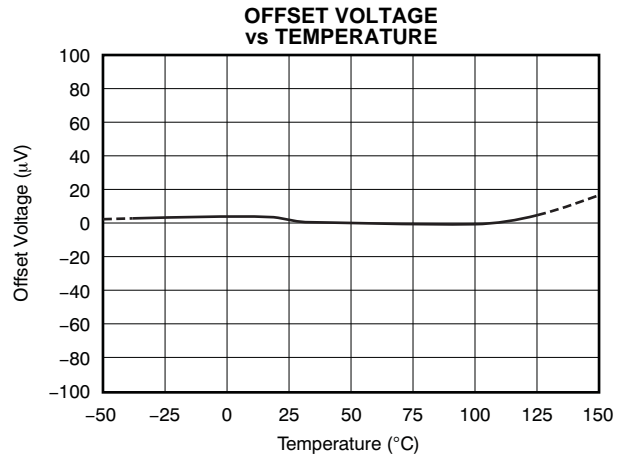

Figure 2.

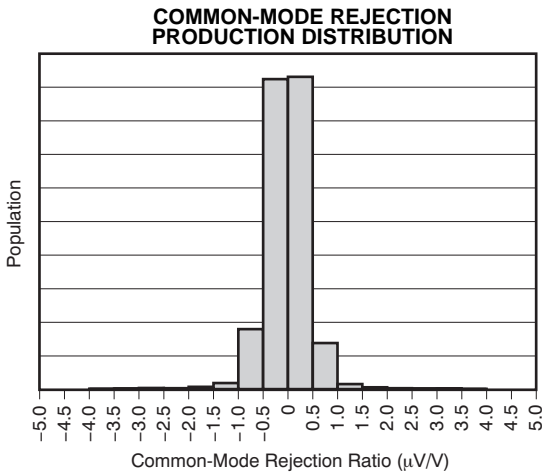

Figure 3.

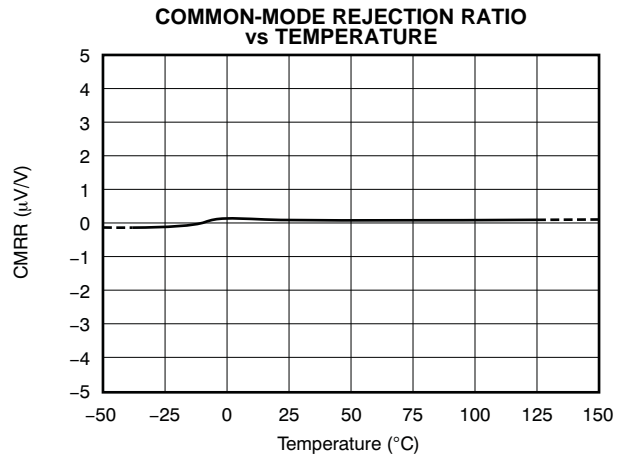

Figure 4.

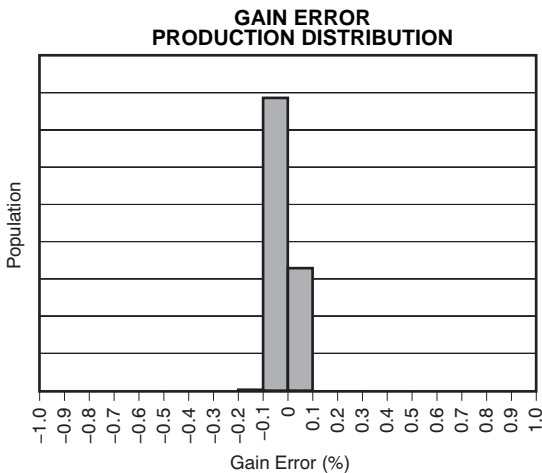

Figure 5.

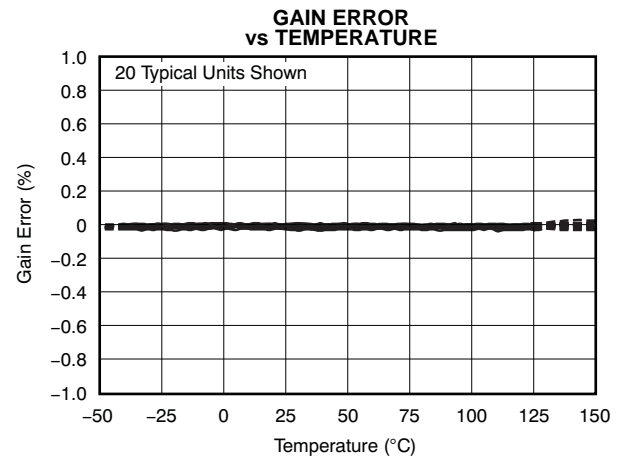

Figure 6.

TYPICAL CHARACTERISTICS (continued)

The INA210 is used for typical characteristics at $T_A = +25^\circ\text{C}$, $V_S = +5\text{V}$, $V_{IN+} = 12\text{V}$, and $V_{REF} = V_S/2$, unless otherwise noted.

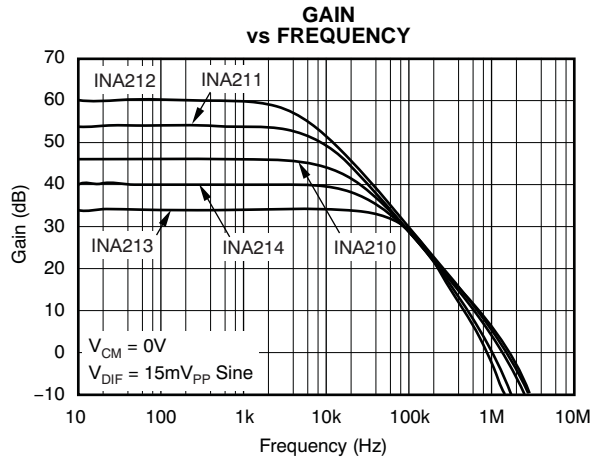

Figure 7.

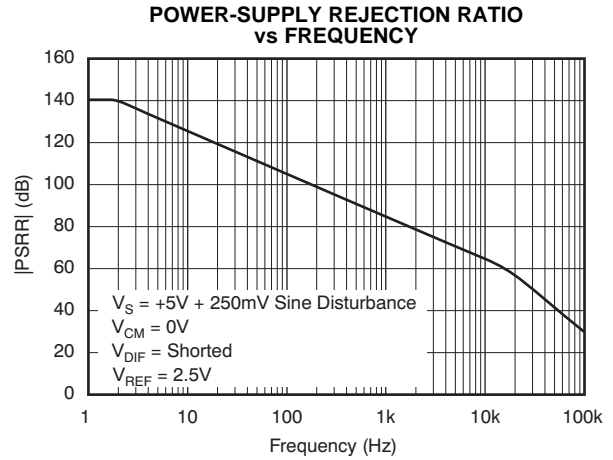

Figure 8.

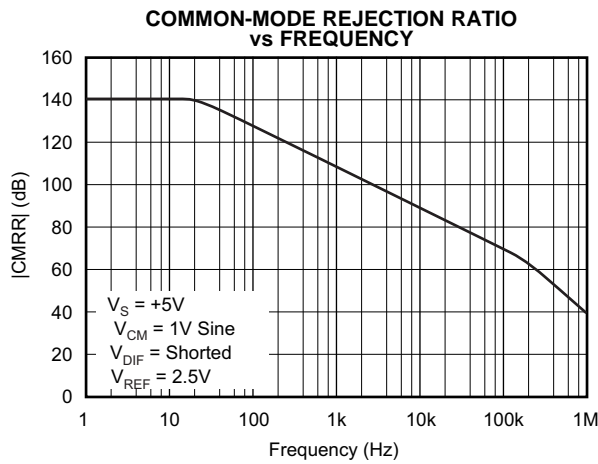

Figure 9.

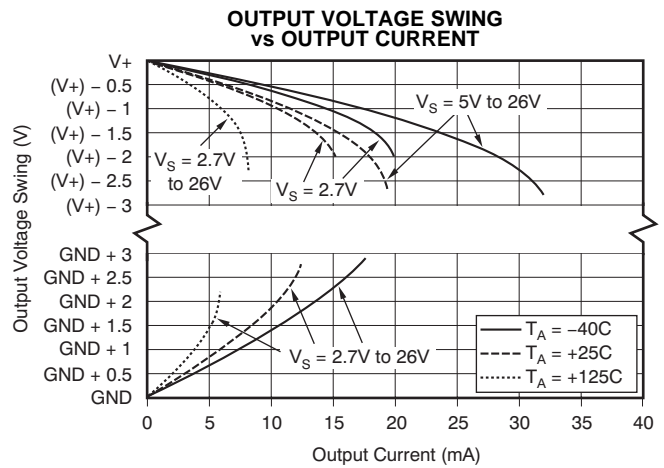

Figure 10.

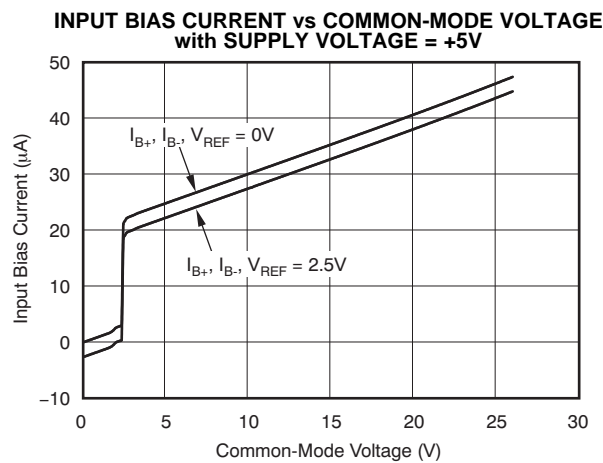

Figure 11.

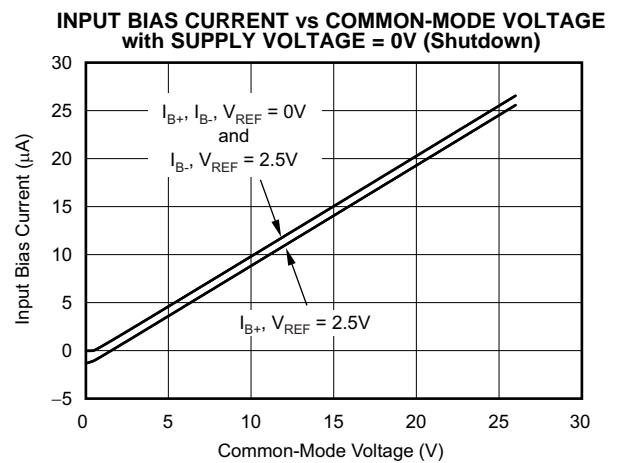

Figure 12.

TYPICAL CHARACTERISTICS (continued)

The INA210 is used for typical characteristics at $T_A = +25^\circ\text{C}$, $V_S = +5\text{V}$, $V_{IN+} = 12\text{V}$, and $V_{REF} = V_S/2$, unless otherwise noted.

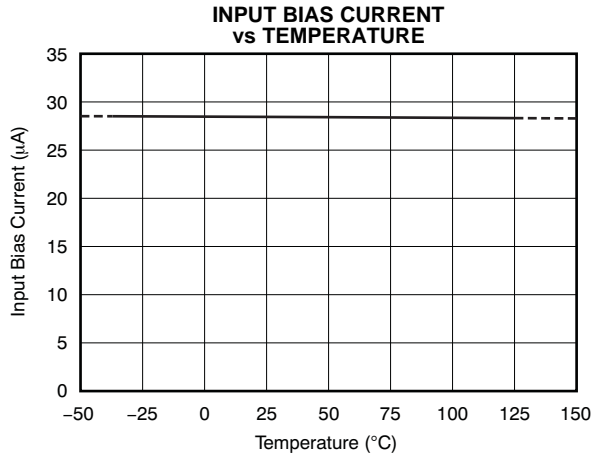

Figure 13.

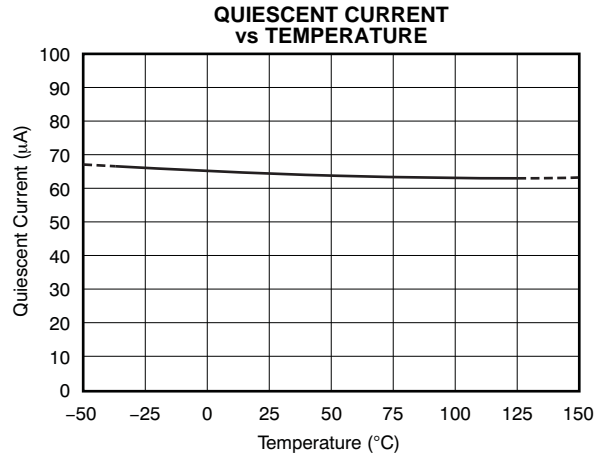

Figure 14.

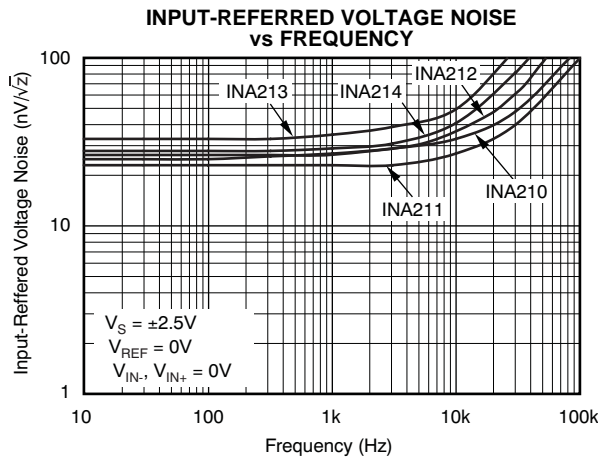

Figure 15.

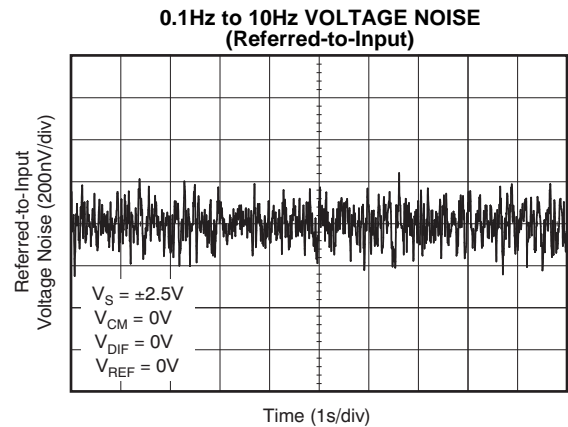

Figure 16.

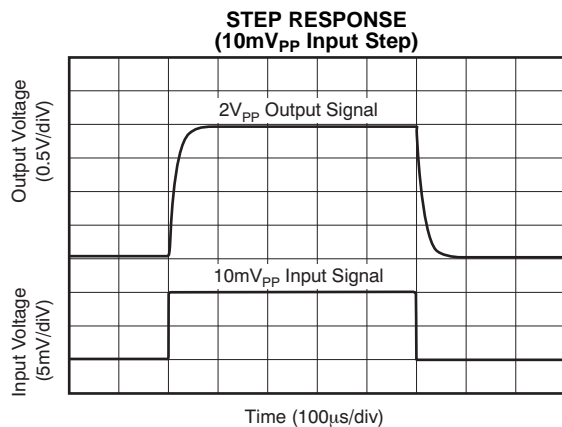

Figure 17.

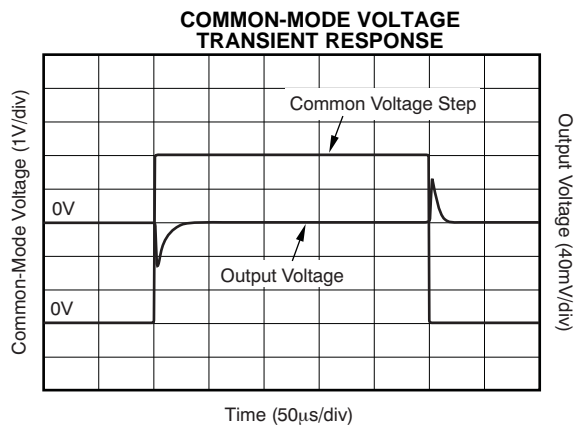

Figure 18.

TYPICAL CHARACTERISTICS (continued)

The INA210 is used for typical characteristics at $T_A = +25^\circ\text{C}$, $V_S = +5\text{V}$, $V_{IN+} = 12\text{V}$, and $V_{REF} = V_S/2$, unless otherwise noted.

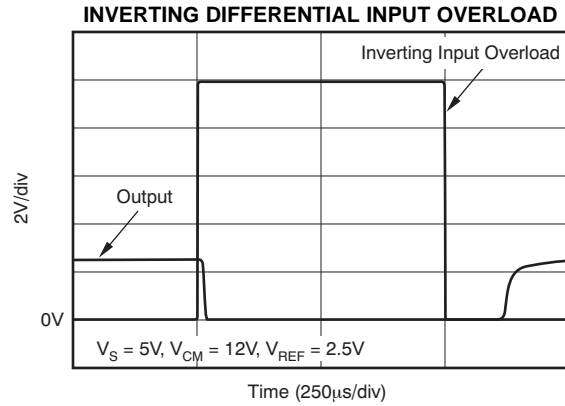

Figure 19.

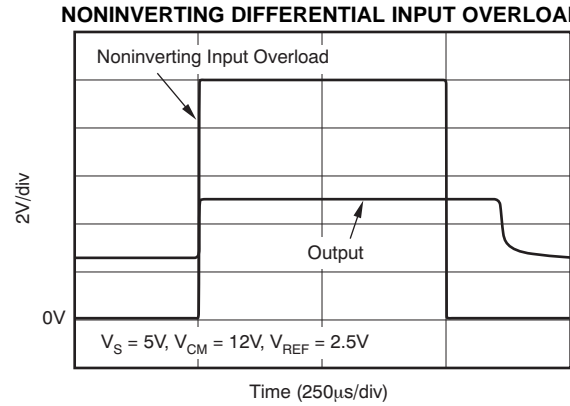

Figure 20.

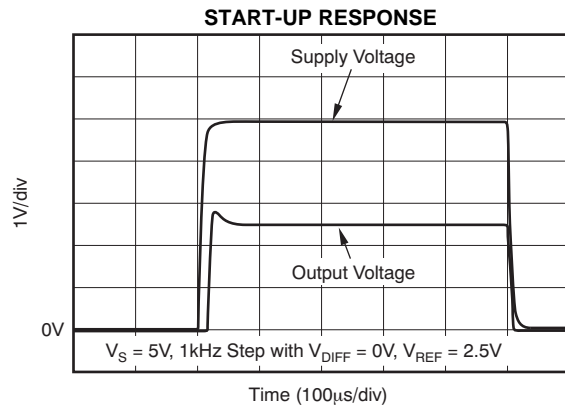

Figure 21.

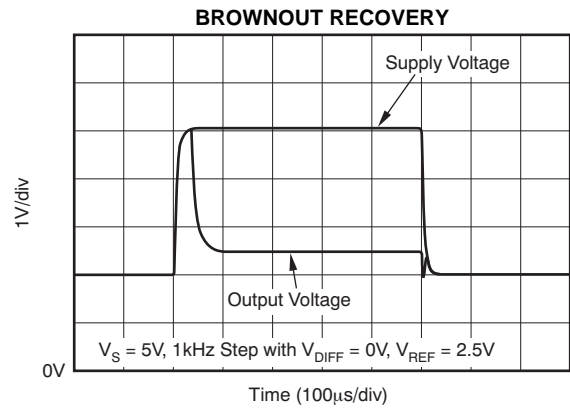

Figure 22.

APPLICATION INFORMATION

BASIC CONNECTIONS

Figure 23 shows the basic connections of the INA210-INA214. The input pins, IN+ and IN–, should be connected as closely as possible to the shunt resistor to minimize any resistance in series with the shunt resistance.

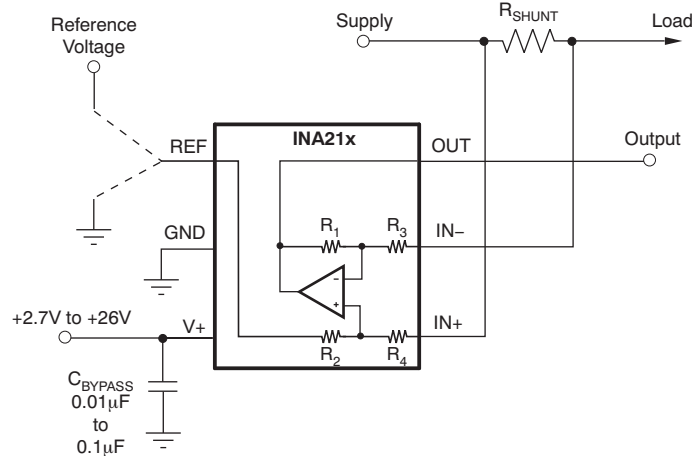

Figure 23. Typical Application

Power-supply bypass capacitors are required for stability. Applications with noisy or high impedance power supplies may require additional decoupling capacitors to reject power-supply noise. Connect bypass capacitors close to the device pins.

On the RSW package, two pins are provided for each input. These pins should be tied together (that is, tie IN+ to IN+ and tie IN– to IN–).

POWER SUPPLY

The input circuitry of the INA210-INA214 can accurately measure beyond its power-supply voltage, V+. For example, the V+ power supply can be 5V, whereas the load power supply voltage can be as high as +26V. However, the output voltage range of the OUT terminal is limited by the voltages on the power-supply pin. Note also that the INA210-INA214 can withstand the full –0.3V to +26V in the input pins, regardless of whether the device has power applied or not.

SELECTING R_s

The zero-drift offset performance of the INA210-INA214 offers several benefits. Most often, the primary advantage of the low offset characteristic enables lower full-scale drops across the shunt. For example, non-zero-drift current shunt monitors typically require a full-scale range of 100mV.

The INA210-INA214 series gives equivalent accuracy at a full-scale range on the order of 10mV. This accuracy reduces shunt dissipation by an order of magnitude with many additional benefits.

Alternatively, there are applications that must measure current over a wide dynamic range that can take advantage of the low offset on the low end of the measurement. Most often, these applications can use the lower gain INA213 or INA214 to accommodate larger shunt drops on the upper end of the scale. For instance, an INA213 operating on a 3.3V supply could easily handle a full-scale shunt drop of 60mV, with only 100 μ V of offset.

UNIDIRECTIONAL OPERATION

Unidirectional operation allows the INA210-INA214 to measure currents through a resistive shunt in one direction. The most frequent case of unidirectional operation sets the output at ground by connecting the REF pin to ground. In unidirectional applications where the highest possible accuracy is desirable at very low inputs, bias the REF pin to a convenient value above 50mV to get the device output swing into the linear range for zero inputs.

A less frequent case of unipolar output biasing is to bias the output by connecting the REF pin to the supply; in this case, the quiescent output for zero input is at quiescent supply. This configuration would only respond to negative currents (inverted voltage polarity at the device input).

BIDIRECTIONAL OPERATION

Bidirectional operation allows the INA210-INA214 to measure currents through a resistive shunt in two directions. In this case, the output can be set anywhere within the limits of what the reference inputs allow (that is, between 0V to V+). Typically, it is set at half-scale for equal range in both directions. In some cases, however, it is set at a voltage other than half-scale when the bidirectional current is nonsymmetrical.

The quiescent output voltage is set by applying voltage to the reference input. Under zero differential input conditions the output assumes the same voltage as is applied to the reference input.

INPUT FILTERING

An obvious and straightforward filtering location is at the device output. However, this location negates the advantage of the low output impedance of the internal buffer. The only other filtering option is at the device input pins. This location, though, does require consideration of the $\pm 30\%$ tolerance of the internal resistances. [Figure 24](#) shows a filter placed at the inputs pins.

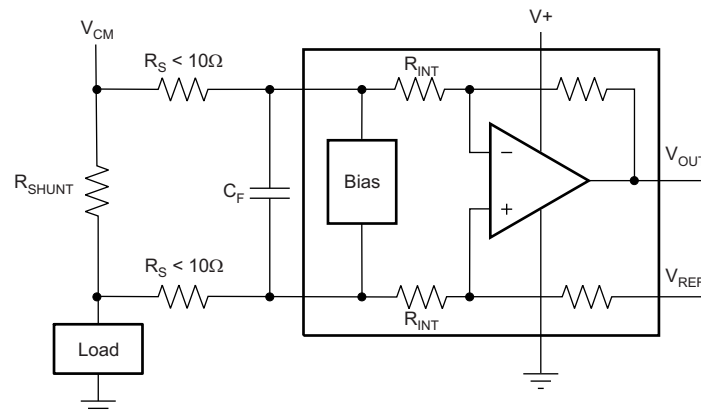

Figure 24. Filter at Input Pins

The addition of external series resistance, however, creates an additional error in the measurement so the value of these series resistors should be kept to 10Ω or less if possible to reduce impact to accuracy.. The internal bias network shown in [Figure 24](#) present at the input pins creates a mismatch in input bias currents when a differential voltage is applied between the input pins. If additional external series filter resistors are added to the circuit, the mismatch in bias currents results in a mismatch of voltage drops across the filter resistors. This mismatch creates a differential error voltage that subtracts from the voltage developed at the shunt resistor. This error results in a voltage at the device input pins that is different than the voltage developed across the shunt resistor. Without the additional series resistance, the mismatch in input bias currents has little effect on device operation. The amount of error these external filter resistor add to the measurement can be calculated using [Equation 2](#) where the gain error factor is calculated using [Equation 1](#).

The amount of variance in the differential voltage present at the device input relative to the voltage developed at the shunt resistor is based both on the external series resistance value as well as the internal input resistors, R3 and R4 (or R_{INT} as shown in [Figure 24](#)). The reduction of the shunt voltage reaching the device input pins appears as a gain error when comparing the output voltage relative to the voltage across the shunt resistor. A factor can be calculated to determine the amount of gain error that is introduced by the addition of external series resistance. The equation used to calculate the expected deviation from the shunt voltage to what is seen at the device input pins is given in [Equation 1](#):

$$\text{Gain Error Factor} = \frac{(1250 \times R_{INT})}{(1250 \times R_S) + (1250 \times R_{INT}) + (R_S \times R_{INT})}$$

where:

R_{INT} is the internal input resistor (R3 and R4), and

R_S is the external series resistance.

(1)

With the adjustment factor equation including the device internal input resistance, this factor varies with each gain version, as shown in [Table 1](#). Each individual device gain error factor is shown in [Table 2](#).

Table 1. Input Resistance

PRODUCT	GAIN	R_{INT} (k Ω)
INA210	200	5
INA211	500	2
INA212	1000	1
INA213	50	20
INA214	100	10

Table 2. Device Gain Error Factor

PRODUCT	SIMPLIFIED GAIN ERROR FACTOR
INA210	$\frac{1000}{R_S + 1000}$
INA211	$\frac{10,000}{(13 \times R_S) + 10,000}$
INA212	$\frac{5000}{(9 \times R_S) + 5000}$
INA213	$\frac{20,000}{(17 \times R_S) + 20,000}$
INA214	$\frac{10,000}{(9 \times R_S) + 10,000}$

The gain error that can be expected from the addition of the external series resistors can then be calculated based on [Equation 2](#):

$$\text{Gain Error (\%)} = 100 - (100 \times \text{Gain Error Factor})$$

(2)

For example, using an INA212 and the corresponding gain error equation from [Table 2](#), a series resistance of 10 Ω results in a gain error factor of 0.982. The corresponding gain error is then calculated using [Equation 2](#), resulting in a gain error of approximately 1.77% solely because of the external 10 Ω series resistors. Using an INA213 with the same 10 Ω series resistor results in a gain error factor of 0.991 and a gain error of 0.84% again solely because of these external resistors.

SHUTTING DOWN THE INA210-INA214 SERIES

While the INA210-INA214 series does not have a shutdown pin, its low power consumption allows powering from the output of a logic gate or transistor switch that can turn on and turn off the INA210-INA214 power-supply quiescent current.

However, in current shunt monitoring applications, there is also a concern for how much current is drained from the shunt circuit in shutdown conditions. Evaluating this current drain involves considering the simplified schematic of the INA210-INA214 in shutdown mode shown in Figure 25.

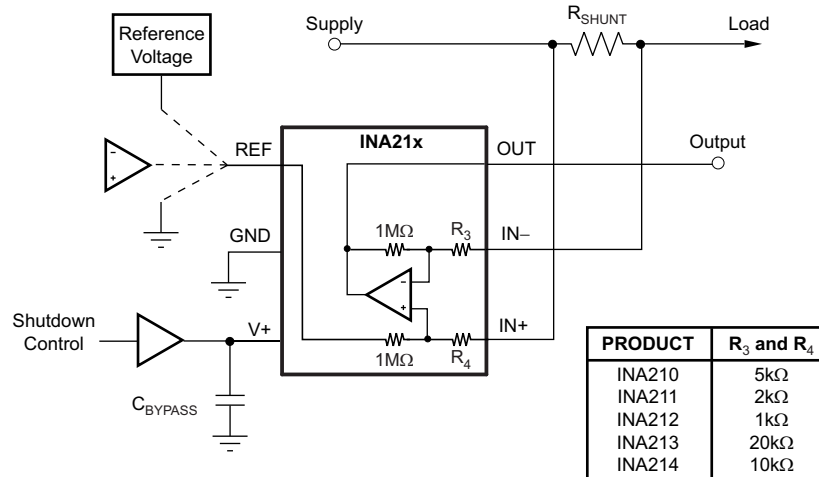

NOTE: 1MΩ paths from shunt inputs to reference and INA21x outputs.

Figure 25. Basic Circuit for Shutting Down INA210-INA214 with Grounded Reference

Note that there is typically slightly more than 1MΩ impedance (from the combination of 1MΩ feedback and 5kΩ input resistors) from each input of the INA210-INA214 to the OUT pin and to the REF pin. The amount of current flowing through these pins depends on the respective ultimate connection. For example, if the REF pin is grounded, the calculation of the effect of the 1MΩ impedance from the shunt to ground is straightforward. However, if the reference or op amp is powered while the INA210-INA214 is shut down, the calculation is direct; instead of assuming 1MΩ to ground, however, assume 1MΩ to the reference voltage. If the reference or op amp is also shut down, some knowledge of the reference or op amp output impedance under shutdown conditions is required. For instance, if the reference source behaves as an open circuit when it is unpowered, little or no current flows through the 1MΩ path.

Regarding the 1MΩ path to the output pin, the output stage of a disabled INA210-INA214 does constitute a good path to ground; consequently, this current is directly proportional to a shunt common-mode voltage impressed across a 1MΩ resistor.

As a final note, when the device is powered up, there is an additional, nearly constant, and well-matched 25μA that flows in each of the inputs as long as the shunt common-mode voltage is 3V or higher. Below 2V common-mode, the only current effects are the result of the 1MΩ resistors.

REF INPUT IMPEDANCE EFFECTS

As with any difference amplifier, the INA210-INA214 series common-mode rejection ratio is affected by any impedance present at the REF input. This concern is not a problem when the REF pin is connected directly to most references or power supplies. When using resistive dividers from the power supply or a reference voltage, the REF pin should be buffered by an op amp.

In systems where the INA210-INA214 output can be sensed differentially, such as by a differential input analog-to-digital converter (ADC) or by using two separate ADC inputs, the effects of external impedance on the REF input can be cancelled. [Figure 26](#) depicts a method of taking the output from the INA210-INA214 by using the REF pin as a reference.

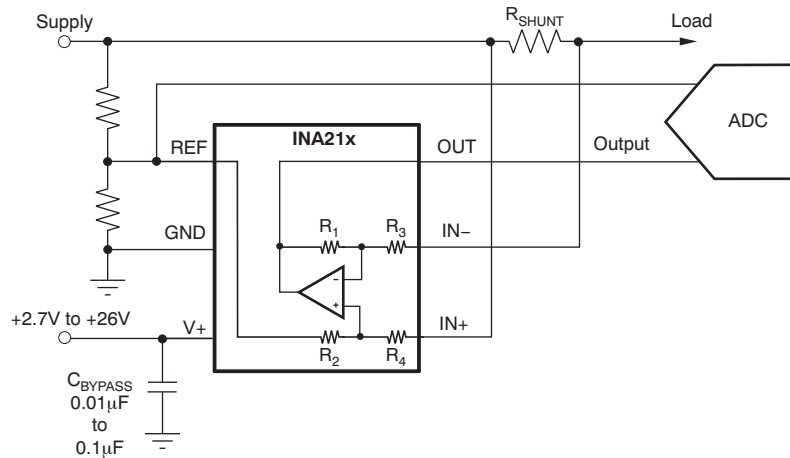

Figure 26. Sensing INA210-INA214 to Cancel Effects of Impedance on the REF Input

USING THE INA210 WITH COMMON-MODE TRANSIENTS ABOVE 26V

With a small amount of additional circuitry, the INA210-INA214 series can be used in circuits subject to transients higher than 26V, such as automotive applications. Use only zener diode or zener-type transient absorbers (sometimes referred to as *Transzorbs*)— any other type of transient absorber has an unacceptable time delay. Start by adding a pair of resistors as shown in Figure 27 as a working impedance for the zener. It is desirable to keep these resistors as small as possible, most often around 10Ω. Larger values can be used with an effect on gain that is discussed in the section on input filtering. Because this circuit is limiting only short-term transients, many applications are satisfied with a 10Ω resistor along with conventional zener diodes of the lowest power rating that can be found. This combination uses the least amount of board space. These diodes can be found in packages as small as SOT-523 or SOD-523.

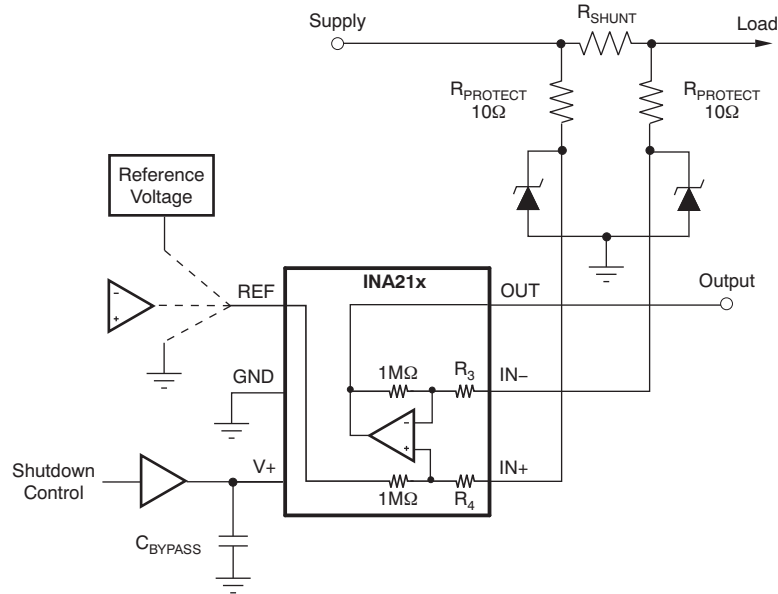

Figure 27. INA210-INA214 Transient Protection Using Dual Zener Diodes

In the event that low-power zeners do not have sufficient transient absorption capability and a higher power transzorb must be used, the most package-efficient solution then involves using a single transzorb and back-to-back diodes between the device inputs. The most space-efficient solutions are dual series-connected diodes in a single SOT-523 or SOD-523 package. This method is shown in Figure 28. In either of these examples, the total board area required by the INA210-INA214 with all protective components is less than that of an SO-8 package, and only slightly greater than that of an MSOP-8 package.

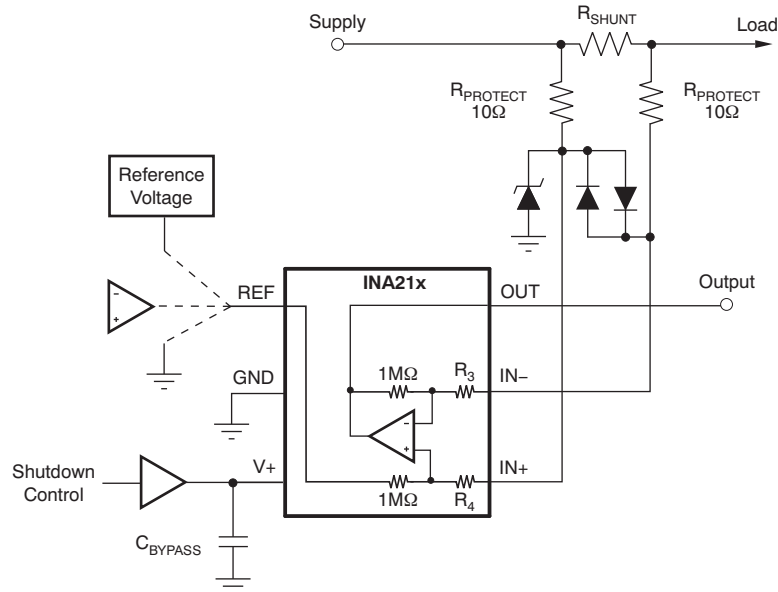

Figure 28. INA210-INA214 Transient Protection Using a Single Transzorb and Input Clamps

IMPROVING TRANSIENT ROBUSTNESS

Applications involving large input transients with excessive dV/dt above 2kV per microsecond present at the device input pins may cause damage to the internal ESD structures on version A devices. This potential damage is a result of the internal latching of the ESD structure to ground when this transient occurs at the input. With significant current available in most current-sensing applications, the large current flowing through the input transient-triggered, ground-shorted ESD structure quickly results in damage to the silicon. External filtering can be used to attenuate the transient signal prior to reaching the inputs to avoid the latching condition. Care must be taken to ensure that external series input resistance does not significantly impact gain error accuracy. For accuracy purposes, these resistances should be kept under 10Ω if possible. Ferrite beads are recommended for this filter because of their inherently low dc ohmic value. Ferrite beads with less than 10Ω of resistance at dc and over 600Ω of resistance at 100MHz to 200MHz are recommended. The recommended capacitor values for this filter are between $0.01\mu\text{F}$ and $0.1\mu\text{F}$ to ensure adequate attenuation in the high-frequency region. This protection scheme is shown in Figure 29.

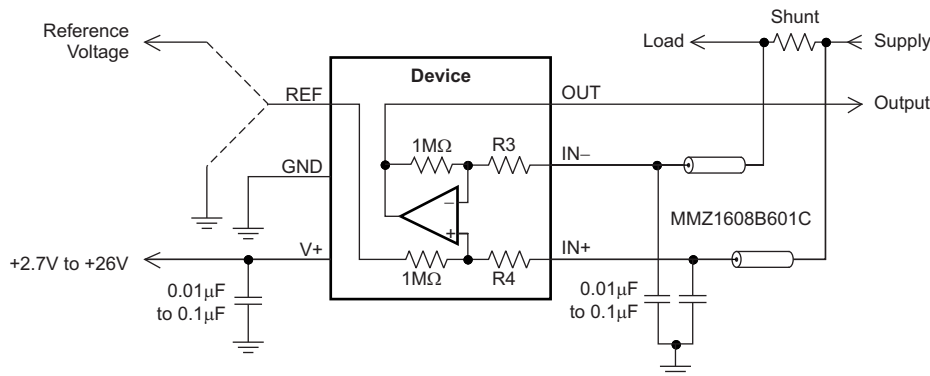

Figure 29. Transient Protection

To minimize the cost of adding these external components to protect the device in applications where large transient signals may be present, version B devices are now available with new ESD structures that are not susceptible to this latching condition. Version B devices are incapable of sustaining these damage causing latched conditions so they do not have the same sensitivity to the transients that the version A devices have, thus making the version B devices a better fit for these applications.

REVISION HISTORY

NOTE: Page numbers for previous revisions may differ from page numbers in the current version.

Changes from Revision D (November 2012) to Revision E Page

- Deleted Package Marking column from Package/Ordering Information table 2
-

Changes from Revision C (August 2012) to Revision D Page

- Changed Frequency Response, *Bandwidth* parameter in Electrical Characteristics table 3
-

Changes from Revision B (June 2009) to Revision C Page

- Changed Package/Ordering table to show both silicon versions A and B 2
 - Added silicon version B ESD ratings to Abs Max table 2
 - Added silicon version B row to Input, *Common-Mode Input Range* parameter in Electrical Characteristics table 3
 - Corrected typo in [Figure 9](#) 6
 - Updated [Figure 12](#) 6
 - Changed *Input Filtering* section 10
 - Added *Improving Transient Robustness* section 16
-

Changes from Revision A (June 2008) to Revision B Page

- Added RSW package to device photo 1
 - Added QFN package to *Features* list 1
 - Updated front page graphic 1
 - Added RSW ordering information to *Package/Ordering Information* table 2
 - Added footnote 3 to *Electrical Characteristics* table 3
 - Added QFN package information to *Temperature Range* section of *Electrical Characteristics* table 3
 - Added RSW package pin out drawing 4
 - Changed [Figure 2](#) to reflect operating temperature range 5
 - Changed [Figure 4](#) to reflect operating temperature range 5
 - Changed [Figure 6](#) to reflect operating temperature range 5
 - Changed [Figure 13](#) to reflect operating temperature range 7
 - Changed [Figure 14](#) to reflect operating temperature range 7
 - Added RSW description to the *Basic Connections* section 9
 - Changed 60µV to 100µV in last sentence of the *Selecting RS* section 9
-

Changes from Original (May 2008) to Revision A Page

- Changed availability of INA211 and INA212 to currently available in *Package/Ordering Information* table 2
 - Deleted first footnote of *Electrical Characteristics* table 3
 - Changed [Figure 7](#) 5
 - Changed [Figure 15](#) 7
-

PACKAGING INFORMATION

Orderable Device	Status (1)	Package Type	Package Drawing	Pins	Package Qty	Eco Plan (2)	Lead/Ball Finish	MSL Peak Temp (3)	Op Temp (°C)	Device Marking (4/5)	Samples
INA210AIDCKR	ACTIVE	SC70	DCK	6	3000	Green (RoHS & no Sb/Br)	CU NIPDAU	Level-2-260C-1 YEAR	-40 to 125	CET	Samples
INA210AIDCKRG4	ACTIVE	SC70	DCK	6	3000	Green (RoHS & no Sb/Br)	CU NIPDAU	Level-2-260C-1 YEAR	-40 to 125	CET	Samples
INA210AIDCKT	ACTIVE	SC70	DCK	6	250	Green (RoHS & no Sb/Br)	CU NIPDAU	Level-2-260C-1 YEAR	-40 to 125	CET	Samples
INA210AIDCKTG4	ACTIVE	SC70	DCK	6	250	Green (RoHS & no Sb/Br)	CU NIPDAU	Level-2-260C-1 YEAR	-40 to 125	CET	Samples
INA210AIRSWR	ACTIVE	UQFN	RSW	10	3000	Green (RoHS & no Sb/Br)	CU NIPDAU	Level-1-260C-UNLIM	-40 to 125	KNJ	Samples
INA210AIRSWT	ACTIVE	UQFN	RSW	10	250	Green (RoHS & no Sb/Br)	CU NIPDAU	Level-1-260C-UNLIM	-40 to 125	(KNJ ~ NSJ)	Samples
INA210BIDCKR	ACTIVE	SC70	DCK	6	3000	Green (RoHS & no Sb/Br)	CU NIPDAU	Level-2-260C-1 YEAR	-40 to 125	SED	Samples
INA210BIDCKT	ACTIVE	SC70	DCK	6	250	Green (RoHS & no Sb/Br)	CU NIPDAU	Level-2-260C-1 YEAR	-40 to 125	SED	Samples
INA211AIDCKR	ACTIVE	SC70	DCK	6	3000	Green (RoHS & no Sb/Br)	CU NIPDAU	Level-2-260C-1 YEAR	-40 to 125	CEU	Samples
INA211AIDCKRG4	ACTIVE	SC70	DCK	6	3000	Green (RoHS & no Sb/Br)	CU NIPDAU	Level-2-260C-1 YEAR	-40 to 125	CEU	Samples
INA211AIDCKT	ACTIVE	SC70	DCK	6	250	Green (RoHS & no Sb/Br)	CU NIPDAU	Level-2-260C-1 YEAR	-40 to 125	CEU	Samples
INA211AIDCKTG4	ACTIVE	SC70	DCK	6	250	Green (RoHS & no Sb/Br)	CU NIPDAU	Level-2-260C-1 YEAR	-40 to 125	CEU	Samples
INA211BIDCKR	ACTIVE	SC70	DCK	6	3000	Green (RoHS & no Sb/Br)	CU NIPDAU	Level-2-260C-1 YEAR	-40 to 125	SEE	Samples
INA211BIDCKT	ACTIVE	SC70	DCK	6	250	Green (RoHS & no Sb/Br)	CU NIPDAU	Level-2-260C-1 YEAR	-40 to 125	SEE	Samples
INA212AIDCKR	ACTIVE	SC70	DCK	6	3000	Green (RoHS & no Sb/Br)	CU NIPDAU	Level-2-260C-1 YEAR	-40 to 125	CEV	Samples
INA212AIDCKRG4	ACTIVE	SC70	DCK	6	3000	Green (RoHS & no Sb/Br)	CU NIPDAU	Level-2-260C-1 YEAR	-40 to 125	CEV	Samples
INA212AIDCKT	ACTIVE	SC70	DCK	6	250	Green (RoHS & no Sb/Br)	CU NIPDAU	Level-2-260C-1 YEAR	-40 to 125	CEV	Samples

Orderable Device	Status (1)	Package Type	Package Drawing	Pins	Package Qty	Eco Plan (2)	Lead/Ball Finish	MSL Peak Temp (3)	Op Temp (°C)	Device Marking (4/5)	Samples
INA212AIDCKTG4	ACTIVE	SC70	DCK	6	250	Green (RoHS & no Sb/Br)	CU NIPDAU	Level-2-260C-1 YEAR	-40 to 125	CEV	Samples
INA212BIDCKR	ACTIVE	SC70	DCK	6	3000	Green (RoHS & no Sb/Br)	CU NIPDAU	Level-2-260C-1 YEAR	-40 to 125	SEC	Samples
INA212BIDCKT	ACTIVE	SC70	DCK	6	250	Green (RoHS & no Sb/Br)	CU NIPDAU	Level-2-260C-1 YEAR	-40 to 125	SEC	Samples
INA213AIDCKR	ACTIVE	SC70	DCK	6	3000	Green (RoHS & no Sb/Br)	CU NIPDAU	Level-2-260C-1 YEAR	-40 to 125	CFT	Samples
INA213AIDCKRG4	ACTIVE	SC70	DCK	6	3000	Green (RoHS & no Sb/Br)	CU NIPDAU	Level-2-260C-1 YEAR	-40 to 125	CFT	Samples
INA213AIDCKT	ACTIVE	SC70	DCK	6	250	Green (RoHS & no Sb/Br)	CU NIPDAU	Level-2-260C-1 YEAR	-40 to 125	CFT	Samples
INA213AIDCKTG4	ACTIVE	SC70	DCK	6	250	Green (RoHS & no Sb/Br)	CU NIPDAU	Level-2-260C-1 YEAR	-40 to 125	CFT	Samples
INA213AIRSWR	ACTIVE	UQFN	RSW	10	3000	Green (RoHS & no Sb/Br)	CU NIPDAU	Level-1-260C-UNLIM	-40 to 125	KPJ	Samples
INA213AIRSWT	ACTIVE	UQFN	RSW	10	250	Green (RoHS & no Sb/Br)	CU NIPDAU	Level-1-260C-UNLIM	-40 to 125	KPJ	Samples
INA213BIDCKR	ACTIVE	SC70	DCK	6	3000	Green (RoHS & no Sb/Br)	CU NIPDAU	Level-2-260C-1 YEAR	-40 to 125	SEF	Samples
INA213BIDCKT	ACTIVE	SC70	DCK	6	250	Green (RoHS & no Sb/Br)	CU NIPDAU	Level-2-260C-1 YEAR	-40 to 125	SEF	Samples
INA214AIDCKR	ACTIVE	SC70	DCK	6	3000	Green (RoHS & no Sb/Br)	CU NIPDAU	Level-2-260C-1 YEAR	-40 to 125	CFV	Samples
INA214AIDCKRG4	ACTIVE	SC70	DCK	6	3000	Green (RoHS & no Sb/Br)	CU NIPDAU	Level-2-260C-1 YEAR	-40 to 125	CFV	Samples
INA214AIDCKT	ACTIVE	SC70	DCK	6	250	Green (RoHS & no Sb/Br)	CU NIPDAU	Level-2-260C-1 YEAR	-40 to 125	CFV	Samples
INA214AIDCKTG4	ACTIVE	SC70	DCK	6	250	Green (RoHS & no Sb/Br)	CU NIPDAU	Level-2-260C-1 YEAR	-40 to 125	CFV	Samples
INA214AIRSWR	ACTIVE	UQFN	RSW	10	3000	Green (RoHS & no Sb/Br)	CU NIPDAU	Level-1-260C-UNLIM	-40 to 125	KRJ	Samples
INA214AIRSWT	ACTIVE	UQFN	RSW	10	250	Green (RoHS & no Sb/Br)	CU NIPDAU	Level-1-260C-UNLIM	-40 to 125	KRJ	Samples
INA214BIDCKR	ACTIVE	SC70	DCK	6	3000	Green (RoHS & no Sb/Br)	CU NIPDAU	Level-2-260C-1 YEAR	-40 to 125	SEA	Samples

Orderable Device	Status (1)	Package Type	Package Drawing	Pins	Package Qty	Eco Plan (2)	Lead/Ball Finish	MSL Peak Temp (3)	Op Temp (°C)	Device Marking (4/5)	Samples
INA214BIDCKT	ACTIVE	SC70	DCK	6	250	Green (RoHS & no Sb/Br)	CU NIPDAU	Level-2-260C-1 YEAR	-40 to 125	SEA	Samples

(1) The marketing status values are defined as follows:

ACTIVE: Product device recommended for new designs.

LIFEBUY: TI has announced that the device will be discontinued, and a lifetime-buy period is in effect.

NRND: Not recommended for new designs. Device is in production to support existing customers, but TI does not recommend using this part in a new design.

PREVIEW: Device has been announced but is not in production. Samples may or may not be available.

OBSOLETE: TI has discontinued the production of the device.

(2) Eco Plan - The planned eco-friendly classification: Pb-Free (RoHS), Pb-Free (RoHS Exempt), or Green (RoHS & no Sb/Br) - please check <http://www.ti.com/productcontent> for the latest availability information and additional product content details.

TBD: The Pb-Free/Green conversion plan has not been defined.

Pb-Free (RoHS): TI's terms "Lead-Free" or "Pb-Free" mean semiconductor products that are compatible with the current RoHS requirements for all 6 substances, including the requirement that lead not exceed 0.1% by weight in homogeneous materials. Where designed to be soldered at high temperatures, TI Pb-Free products are suitable for use in specified lead-free processes.

Pb-Free (RoHS Exempt): This component has a RoHS exemption for either 1) lead-based flip-chip solder bumps used between the die and package, or 2) lead-based die adhesive used between the die and leadframe. The component is otherwise considered Pb-Free (RoHS compatible) as defined above.

Green (RoHS & no Sb/Br): TI defines "Green" to mean Pb-Free (RoHS compatible), and free of Bromine (Br) and Antimony (Sb) based flame retardants (Br or Sb do not exceed 0.1% by weight in homogeneous material)

(3) MSL, Peak Temp. -- The Moisture Sensitivity Level rating according to the JEDEC industry standard classifications, and peak solder temperature.

(4) There may be additional marking, which relates to the logo, the lot trace code information, or the environmental category on the device.

(5) Multiple Device Markings will be inside parentheses. Only one Device Marking contained in parentheses and separated by a "~" will appear on a device. If a line is indented then it is a continuation of the previous line and the two combined represent the entire Device Marking for that device.

Important Information and Disclaimer: The information provided on this page represents TI's knowledge and belief as of the date that it is provided. TI bases its knowledge and belief on information provided by third parties, and makes no representation or warranty as to the accuracy of such information. Efforts are underway to better integrate information from third parties. TI has taken and continues to take reasonable steps to provide representative and accurate information but may not have conducted destructive testing or chemical analysis on incoming materials and chemicals. TI and TI suppliers consider certain information to be proprietary, and thus CAS numbers and other limited information may not be available for release.

In no event shall TI's liability arising out of such information exceed the total purchase price of the TI part(s) at issue in this document sold by TI to Customer on an annual basis.

OTHER QUALIFIED VERSIONS OF INA214 :

- Automotive: [INA214-Q1](#)

NOTE: Qualified Version Definitions:

- Automotive - Q100 devices qualified for high-reliability automotive applications targeting zero defects

TAPE AND REEL INFORMATION

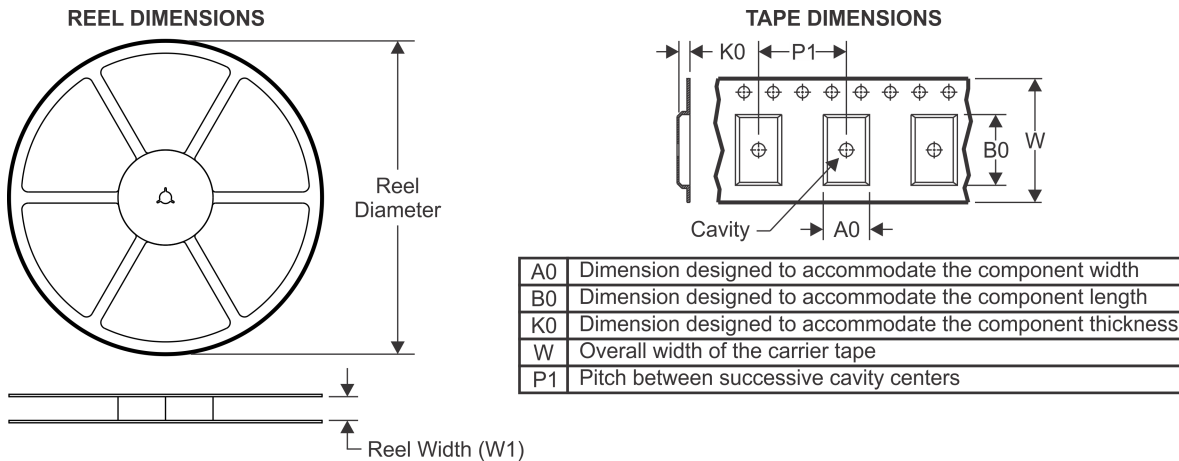

QUADRANT ASSIGNMENTS FOR PIN 1 ORIENTATION IN TAPE



*All dimensions are nominal

Device	Package Type	Package Drawing	Pins	SPQ	Reel Diameter (mm)	Reel Width W1 (mm)	A0 (mm)	B0 (mm)	K0 (mm)	P1 (mm)	W (mm)	Pin1 Quadrant
INA210AIDCKR	SC70	DCK	6	3000	178.0	9.0	2.4	2.5	1.2	4.0	8.0	Q3
INA210AIDCKR	SC70	DCK	6	3000	179.0	8.4	2.2	2.5	1.2	4.0	8.0	Q3
INA210AIDCKT	SC70	DCK	6	250	178.0	9.0	2.4	2.5	1.2	4.0	8.0	Q3
INA210AIDCKT	SC70	DCK	6	250	179.0	8.4	2.2	2.5	1.2	4.0	8.0	Q3
INA210AIDCKT	SC70	DCK	6	250	180.0	8.4	2.25	2.4	1.22	4.0	8.0	Q3
INA210AIRSWR	UQFN	RSW	10	3000	179.0	8.4	1.7	2.1	0.7	4.0	8.0	Q1
INA210AIRSWT	UQFN	RSW	10	250	179.0	8.4	1.7	2.1	0.7	4.0	8.0	Q1
INA210BIDCKR	SC70	DCK	6	3000	178.0	9.0	2.4	2.5	1.2	4.0	8.0	Q3
INA210BIDCKT	SC70	DCK	6	250	178.0	9.0	2.4	2.5	1.2	4.0	8.0	Q3
INA211AIDCKR	SC70	DCK	6	3000	179.0	8.4	2.2	2.5	1.2	4.0	8.0	Q3
INA211AIDCKR	SC70	DCK	6	3000	180.0	8.4	2.25	2.4	1.22	4.0	8.0	Q3
INA211AIDCKT	SC70	DCK	6	250	179.0	8.4	2.2	2.5	1.2	4.0	8.0	Q3
INA211AIDCKT	SC70	DCK	6	250	178.0	9.0	2.4	2.5	1.2	4.0	8.0	Q3
INA211BIDCKR	SC70	DCK	6	3000	178.0	9.0	2.4	2.5	1.2	4.0	8.0	Q3
INA211BIDCKT	SC70	DCK	6	250	178.0	9.0	2.4	2.5	1.2	4.0	8.0	Q3
INA212AIDCKR	SC70	DCK	6	3000	180.0	8.4	2.25	2.4	1.22	4.0	8.0	Q3
INA212AIDCKT	SC70	DCK	6	250	178.0	9.0	2.4	2.5	1.2	4.0	8.0	Q3
INA212AIDCKT	SC70	DCK	6	250	179.0	8.4	2.2	2.5	1.2	4.0	8.0	Q3

Device	Package Type	Package Drawing	Pins	SPQ	Reel Diameter (mm)	Reel Width W1 (mm)	A0 (mm)	B0 (mm)	K0 (mm)	P1 (mm)	W (mm)	Pin1 Quadrant
INA212AIDCKT	SC70	DCK	6	250	180.0	8.4	2.25	2.4	1.22	4.0	8.0	Q3
INA212BIDCKR	SC70	DCK	6	3000	178.0	9.0	2.4	2.5	1.2	4.0	8.0	Q3
INA212BIDCKT	SC70	DCK	6	250	178.0	9.0	2.4	2.5	1.2	4.0	8.0	Q3
INA213AIDCKR	SC70	DCK	6	3000	179.0	8.4	2.2	2.5	1.2	4.0	8.0	Q3
INA213AIDCKR	SC70	DCK	6	3000	178.0	9.0	2.4	2.5	1.2	4.0	8.0	Q3
INA213AIDCKT	SC70	DCK	6	250	180.0	8.4	2.25	2.4	1.22	4.0	8.0	Q3
INA213AIDCKT	SC70	DCK	6	250	178.0	9.0	2.4	2.5	1.2	4.0	8.0	Q3
INA213AIDCKT	SC70	DCK	6	250	179.0	8.4	2.2	2.5	1.2	4.0	8.0	Q3
INA213AIRSWR	UQFN	RSW	10	3000	179.0	8.4	1.7	2.1	0.7	4.0	8.0	Q1
INA213AIRSWT	UQFN	RSW	10	250	179.0	8.4	1.7	2.1	0.7	4.0	8.0	Q1
INA213BIDCKR	SC70	DCK	6	3000	178.0	9.0	2.4	2.5	1.2	4.0	8.0	Q3
INA213BIDCKT	SC70	DCK	6	250	178.0	9.0	2.4	2.5	1.2	4.0	8.0	Q3
INA214AIDCKR	SC70	DCK	6	3000	179.0	8.4	2.2	2.5	1.2	4.0	8.0	Q3
INA214AIDCKR	SC70	DCK	6	3000	178.0	9.0	2.4	2.5	1.2	4.0	8.0	Q3
INA214AIDCKT	SC70	DCK	6	250	179.0	8.4	2.2	2.5	1.2	4.0	8.0	Q3
INA214AIDCKT	SC70	DCK	6	250	178.0	9.0	2.4	2.5	1.2	4.0	8.0	Q3
INA214AIRSWR	UQFN	RSW	10	3000	179.0	8.4	1.7	2.1	0.7	4.0	8.0	Q1
INA214AIRSWT	UQFN	RSW	10	250	179.0	8.4	1.7	2.1	0.7	4.0	8.0	Q1
INA214BIDCKR	SC70	DCK	6	3000	178.0	9.0	2.4	2.5	1.2	4.0	8.0	Q3
INA214BIDCKT	SC70	DCK	6	250	178.0	9.0	2.4	2.5	1.2	4.0	8.0	Q3

TAPE AND REEL BOX DIMENSIONS



*All dimensions are nominal

Device	Package Type	Package Drawing	Pins	SPQ	Length (mm)	Width (mm)	Height (mm)
INA210AIDCKR	SC70	DCK	6	3000	180.0	180.0	18.0
INA210AIDCKR	SC70	DCK	6	3000	195.0	200.0	45.0
INA210AIDCKT	SC70	DCK	6	250	180.0	180.0	18.0
INA210AIDCKT	SC70	DCK	6	250	195.0	200.0	45.0
INA210AIDCKT	SC70	DCK	6	250	202.0	201.0	28.0
INA210AIRSWR	UQFN	RSW	10	3000	203.0	203.0	35.0
INA210AIRSWT	UQFN	RSW	10	250	203.0	203.0	35.0
INA210BIDCKR	SC70	DCK	6	3000	180.0	180.0	18.0
INA210BIDCKT	SC70	DCK	6	250	180.0	180.0	18.0
INA211AIDCKR	SC70	DCK	6	3000	195.0	200.0	45.0
INA211AIDCKR	SC70	DCK	6	3000	202.0	201.0	28.0
INA211AIDCKT	SC70	DCK	6	250	195.0	200.0	45.0
INA211AIDCKT	SC70	DCK	6	250	180.0	180.0	18.0
INA211BIDCKR	SC70	DCK	6	3000	180.0	180.0	18.0
INA211BIDCKT	SC70	DCK	6	250	180.0	180.0	18.0
INA212AIDCKR	SC70	DCK	6	3000	202.0	201.0	28.0
INA212AIDCKT	SC70	DCK	6	250	180.0	180.0	18.0
INA212AIDCKT	SC70	DCK	6	250	195.0	200.0	45.0
INA212AIDCKT	SC70	DCK	6	250	202.0	201.0	28.0
INA212BIDCKR	SC70	DCK	6	3000	180.0	180.0	18.0
INA212BIDCKT	SC70	DCK	6	250	180.0	180.0	18.0
INA213AIDCKR	SC70	DCK	6	3000	195.0	200.0	45.0
INA213AIDCKR	SC70	DCK	6	3000	180.0	180.0	18.0
INA213AIDCKT	SC70	DCK	6	250	202.0	201.0	28.0
INA213AIDCKT	SC70	DCK	6	250	180.0	180.0	18.0
INA213AIDCKT	SC70	DCK	6	250	195.0	200.0	45.0
INA213AIRSWR	UQFN	RSW	10	3000	203.0	203.0	35.0
INA213AIRSWT	UQFN	RSW	10	250	203.0	203.0	35.0
INA213BIDCKR	SC70	DCK	6	3000	180.0	180.0	18.0
INA213BIDCKT	SC70	DCK	6	250	180.0	180.0	18.0
INA214AIDCKR	SC70	DCK	6	3000	195.0	200.0	45.0
INA214AIDCKR	SC70	DCK	6	3000	180.0	180.0	18.0
INA214AIDCKT	SC70	DCK	6	250	195.0	200.0	45.0
INA214AIDCKT	SC70	DCK	6	250	180.0	180.0	18.0
INA214AIRSWR	UQFN	RSW	10	3000	203.0	203.0	35.0
INA214AIRSWT	UQFN	RSW	10	250	203.0	203.0	35.0
INA214BIDCKR	SC70	DCK	6	3000	180.0	180.0	18.0
INA214BIDCKT	SC70	DCK	6	250	180.0	180.0	18.0

DCK (R-PDSO-G6)

PLASTIC SMALL-OUTLINE PACKAGE

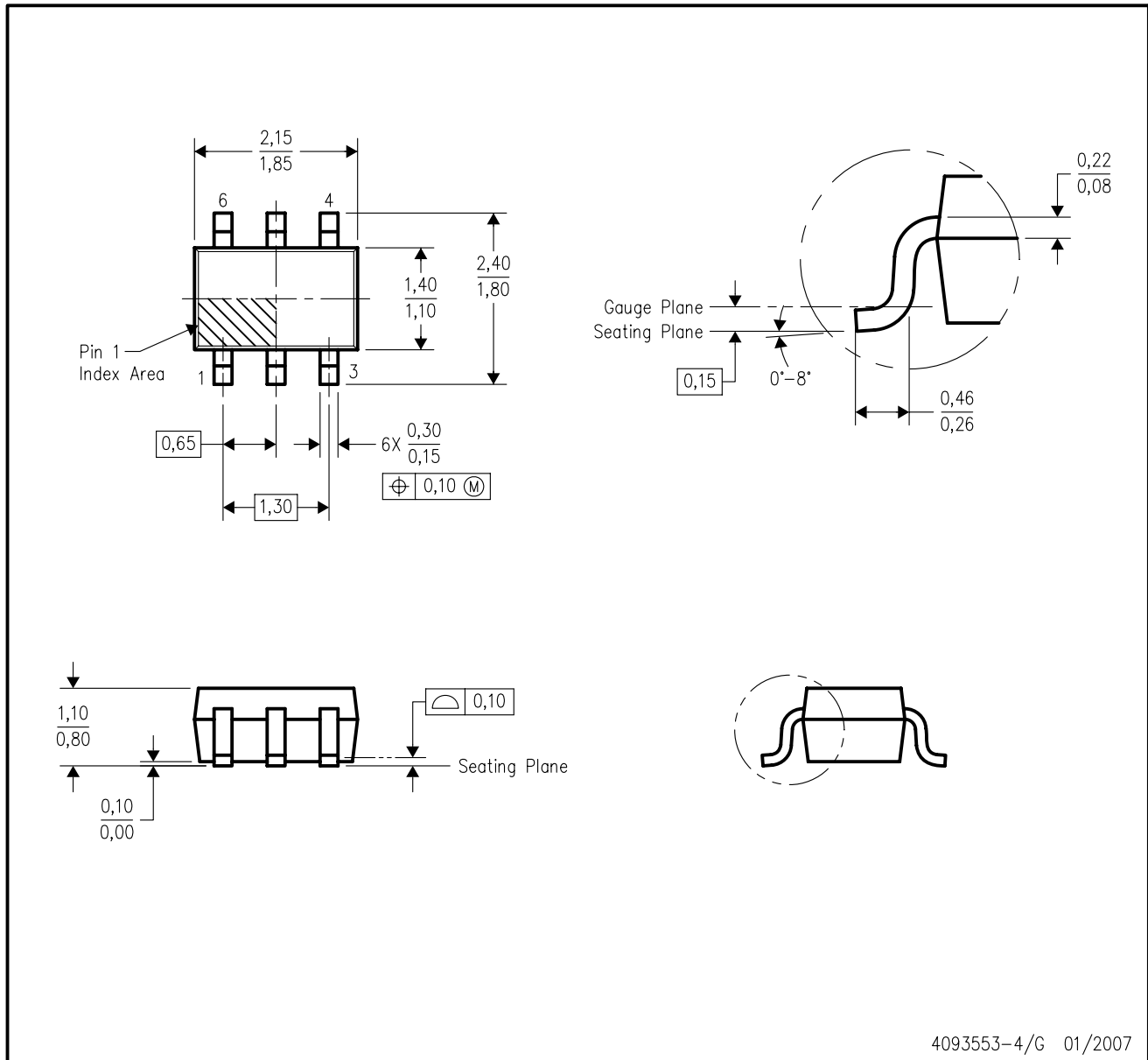

- NOTES:
- A. All linear dimensions are in millimeters.
 - B. This drawing is subject to change without notice.
 - C. Body dimensions do not include mold flash or protrusion. Mold flash and protrusion shall not exceed 0.15 per side.
 - D. Falls within JEDEC MO-203 variation AB.

DCK (R-PDSO-G6)

PLASTIC SMALL OUTLINE

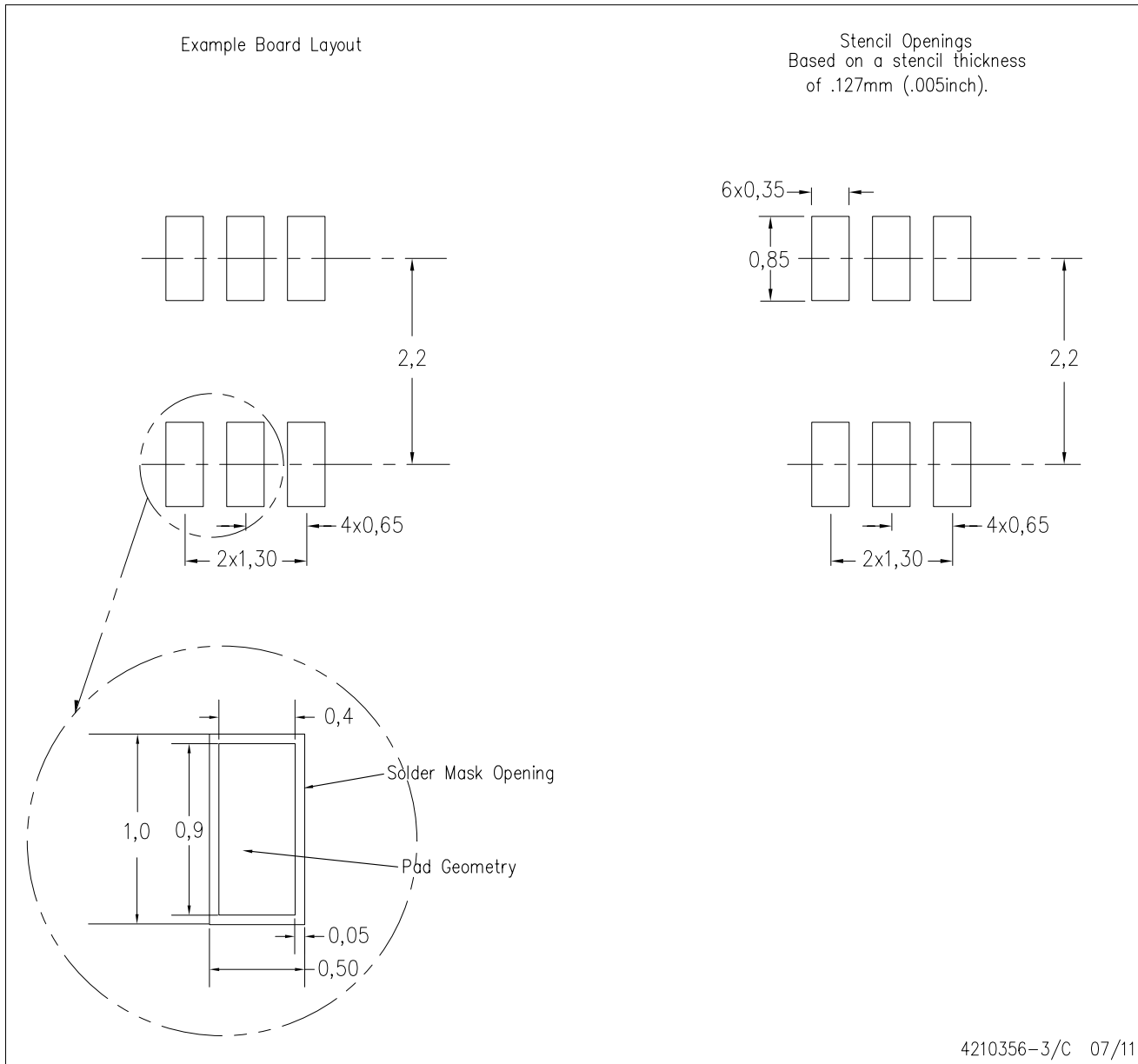

- NOTES:
- All linear dimensions are in millimeters.
 - This drawing is subject to change without notice.
 - Customers should place a note on the circuit board fabrication drawing not to alter the center solder mask defined pad.
 - Publication IPC-7351 is recommended for alternate designs.
 - Laser cutting apertures with trapezoidal walls and also rounding corners will offer better paste release. Customers should contact their board assembly site for stencil design recommendations. Example stencil design based on a 50% volumetric metal load solder paste. Refer to IPC-7525 for other stencil recommendations.

RSW (R-PUQFN-N10)

PLASTIC QUAD FLATPACK NO-LEAD

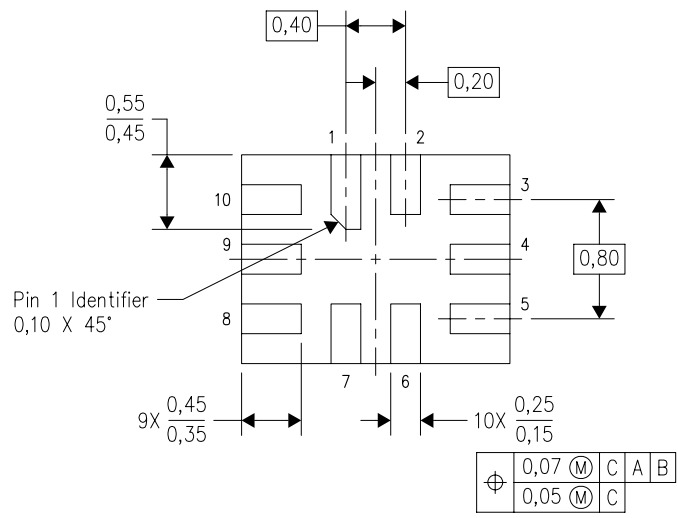
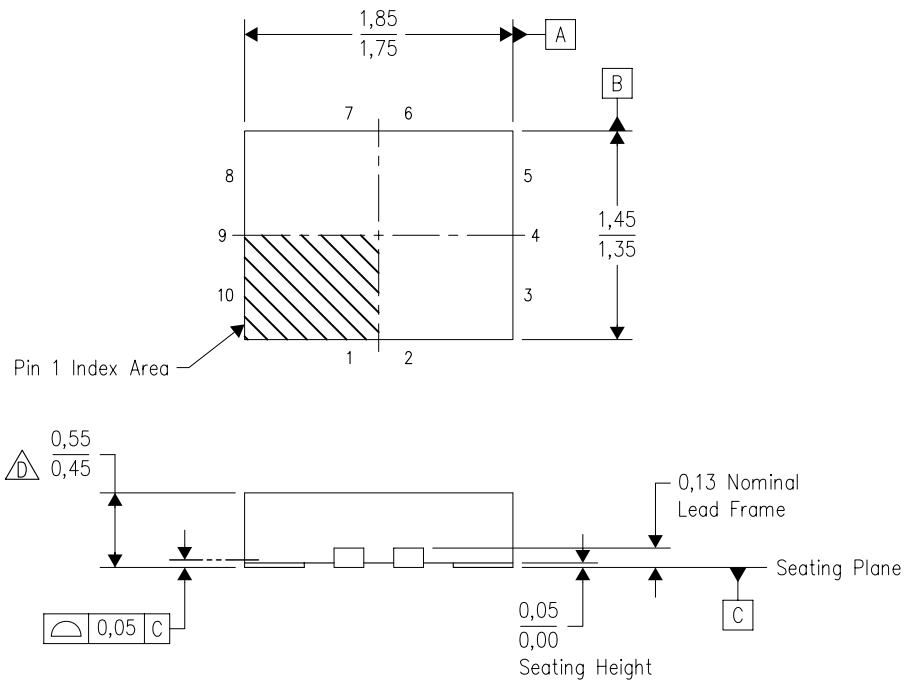

Bottom View

4208097/C 07/2008

- NOTES:
- A. All linear dimensions are in millimeters. Dimensioning and tolerancing per ASME Y14.5M-1994.
 - B. This drawing is subject to change without notice.
 - C. QFN (Quad Flatpack No-lead) package configuration.
 -  This package complies to JEDEC MO-288 variation UDEE, except minimum package height.

RSW (R-PUQFN-N10)

PLASTIC QUAD FLATPACK NO-LEAD

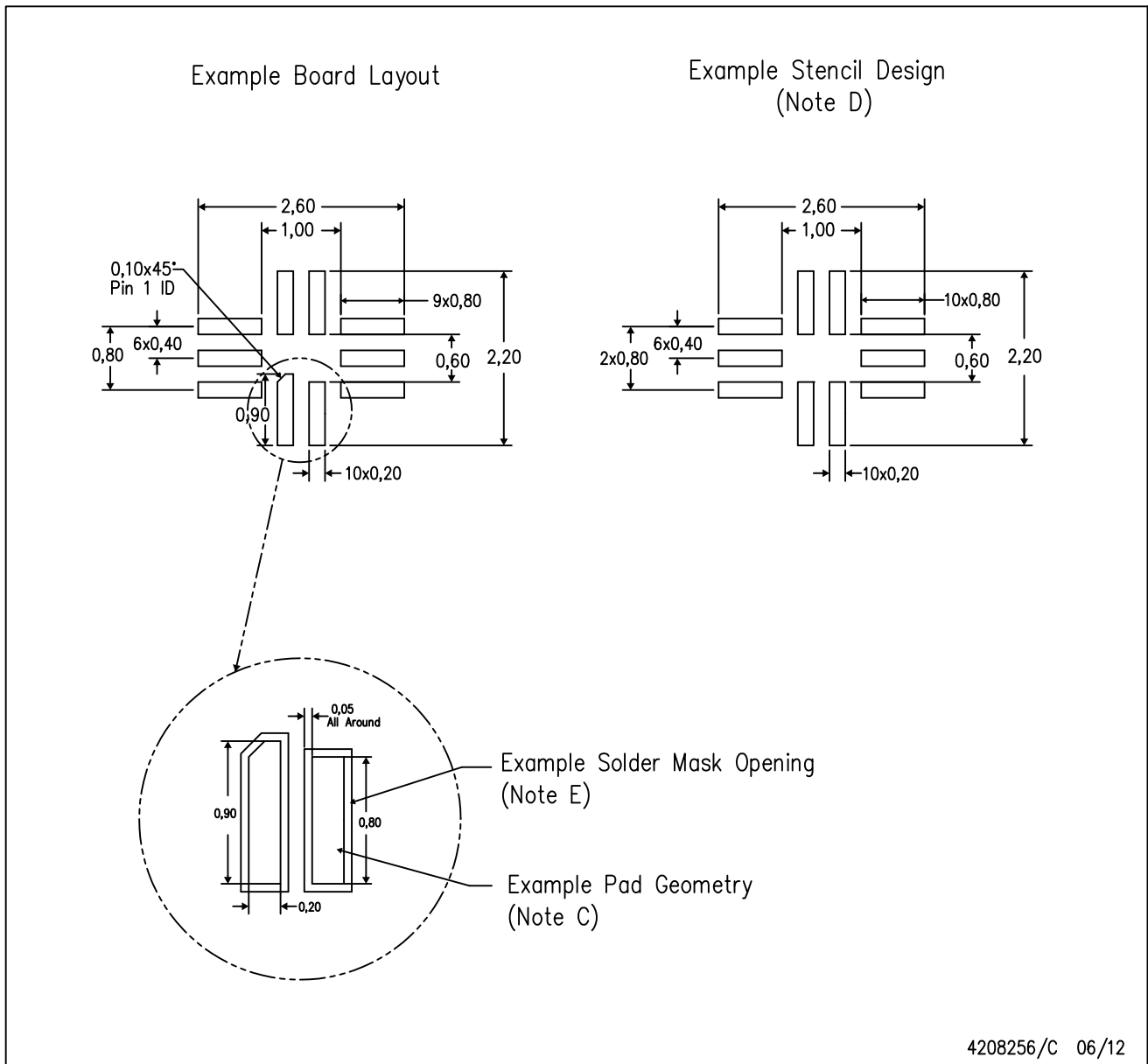

- NOTES:
- All linear dimensions are in millimeters.
 - This drawing is subject to change without notice.
 - Publication IPC-7351 is recommended for alternate designs.
 - Laser cutting apertures with trapezoidal walls and also rounding corners will offer better paste release. Customers should contact their board assembly site for stencil design recommendations. Refer to IPC 7525 for stencil design considerations.
 - Customers should contact their board fabrication site for minimum solder mask web tolerances between signal pads.

IMPORTANT NOTICE

Texas Instruments Incorporated and its subsidiaries (TI) reserve the right to make corrections, enhancements, improvements and other changes to its semiconductor products and services per JESD46, latest issue, and to discontinue any product or service per JESD48, latest issue. Buyers should obtain the latest relevant information before placing orders and should verify that such information is current and complete. All semiconductor products (also referred to herein as "components") are sold subject to TI's terms and conditions of sale supplied at the time of order acknowledgment.

TI warrants performance of its components to the specifications applicable at the time of sale, in accordance with the warranty in TI's terms and conditions of sale of semiconductor products. Testing and other quality control techniques are used to the extent TI deems necessary to support this warranty. Except where mandated by applicable law, testing of all parameters of each component is not necessarily performed.

TI assumes no liability for applications assistance or the design of Buyers' products. Buyers are responsible for their products and applications using TI components. To minimize the risks associated with Buyers' products and applications, Buyers should provide adequate design and operating safeguards.

TI does not warrant or represent that any license, either express or implied, is granted under any patent right, copyright, mask work right, or other intellectual property right relating to any combination, machine, or process in which TI components or services are used. Information published by TI regarding third-party products or services does not constitute a license to use such products or services or a warranty or endorsement thereof. Use of such information may require a license from a third party under the patents or other intellectual property of the third party, or a license from TI under the patents or other intellectual property of TI.

Reproduction of significant portions of TI information in TI data books or data sheets is permissible only if reproduction is without alteration and is accompanied by all associated warranties, conditions, limitations, and notices. TI is not responsible or liable for such altered documentation. Information of third parties may be subject to additional restrictions.

Resale of TI components or services with statements different from or beyond the parameters stated by TI for that component or service voids all express and any implied warranties for the associated TI component or service and is an unfair and deceptive business practice. TI is not responsible or liable for any such statements.

Buyer acknowledges and agrees that it is solely responsible for compliance with all legal, regulatory and safety-related requirements concerning its products, and any use of TI components in its applications, notwithstanding any applications-related information or support that may be provided by TI. Buyer represents and agrees that it has all the necessary expertise to create and implement safeguards which anticipate dangerous consequences of failures, monitor failures and their consequences, lessen the likelihood of failures that might cause harm and take appropriate remedial actions. Buyer will fully indemnify TI and its representatives against any damages arising out of the use of any TI components in safety-critical applications.

In some cases, TI components may be promoted specifically to facilitate safety-related applications. With such components, TI's goal is to help enable customers to design and create their own end-product solutions that meet applicable functional safety standards and requirements. Nonetheless, such components are subject to these terms.

No TI components are authorized for use in FDA Class III (or similar life-critical medical equipment) unless authorized officers of the parties have executed a special agreement specifically governing such use.

Only those TI components which TI has specifically designated as military grade or "enhanced plastic" are designed and intended for use in military/aerospace applications or environments. Buyer acknowledges and agrees that any military or aerospace use of TI components which have **not** been so designated is solely at the Buyer's risk, and that Buyer is solely responsible for compliance with all legal and regulatory requirements in connection with such use.

TI has specifically designated certain components as meeting ISO/TS16949 requirements, mainly for automotive use. In any case of use of non-designated products, TI will not be responsible for any failure to meet ISO/TS16949.

Products

Audio	www.ti.com/audio
Amplifiers	amplifier.ti.com
Data Converters	dataconverter.ti.com
DLP® Products	www.dlp.com
DSP	dsp.ti.com
Clocks and Timers	www.ti.com/clocks
Interface	interface.ti.com
Logic	logic.ti.com
Power Mgmt	power.ti.com
Microcontrollers	microcontroller.ti.com
RFID	www.ti-rfid.com
OMAP Applications Processors	www.ti.com/omap
Wireless Connectivity	www.ti.com/wirelessconnectivity

Applications

Automotive and Transportation	www.ti.com/automotive
Communications and Telecom	www.ti.com/communications
Computers and Peripherals	www.ti.com/computers
Consumer Electronics	www.ti.com/consumer-apps
Energy and Lighting	www.ti.com/energy
Industrial	www.ti.com/industrial
Medical	www.ti.com/medical
Security	www.ti.com/security
Space, Avionics and Defense	www.ti.com/space-avionics-defense
Video and Imaging	www.ti.com/video

TI E2E Community

e2e.ti.com